

## CHT Chain Conveyors

The CHT Chain conveyors are heavy duty, low profile conveyors optimized for pallet transport and also used in cross-chain special conveyors DCR .

The conveyors are constructed from precision manufactured sheet metal parts and the carrying chains run on wear resistant strips for extended chain life and low maintenance.

Factory :New Borg El Arab 2nd Zone  
entrance 2c street 3 - entrance 2c street 5  
Tel:+20-(03)-4624127 - 4624126 - 4624025  
fax : (03) 4624291

[Info@UnitelEgypt.com](mailto:Info@UnitelEgypt.com)

Cairo Office : Corniche El Nile, Maadi, Cairo  
Tel +20:(0)2-25266333  
Fax +20:(0)2-25264888

[Sales@UnitelEgypt.com](mailto:Sales@UnitelEgypt.com)



[www.UnitelEgypt.com](http://www.UnitelEgypt.com)



[/UnitelEgypt](https://www.facebook.com/UnitelEgypt)

# CHT Chain Conveyors

## Features

The CHT chain conveyor is a heavy duty, low profile conveyor optimized for pallet transport.

The conveyor is constructed from precision manufactured sheet metal side channels, and modules are butt coupled for modularity and extended length.



## Characteristics

The special carrying chains run on ultra-high molecular weight polyethylene (UHMWPE) wear-resistant strips, for self-lubrication and extended chain life.

Drive and idler sprockets are made of hardened steel, for long life and low maintenance operation.

The system can be fitted with side guards..

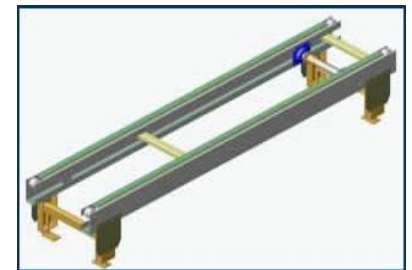

## Applications

CHT conveyors are used in production floors and warehouses to transport pallets and are compatible with the RDS family of heavy loads live roller conveyors and are also used as cross chain members in cross-chain deflectors of the DCR type

# CHT Chain Conveyors

## CHT Specifications

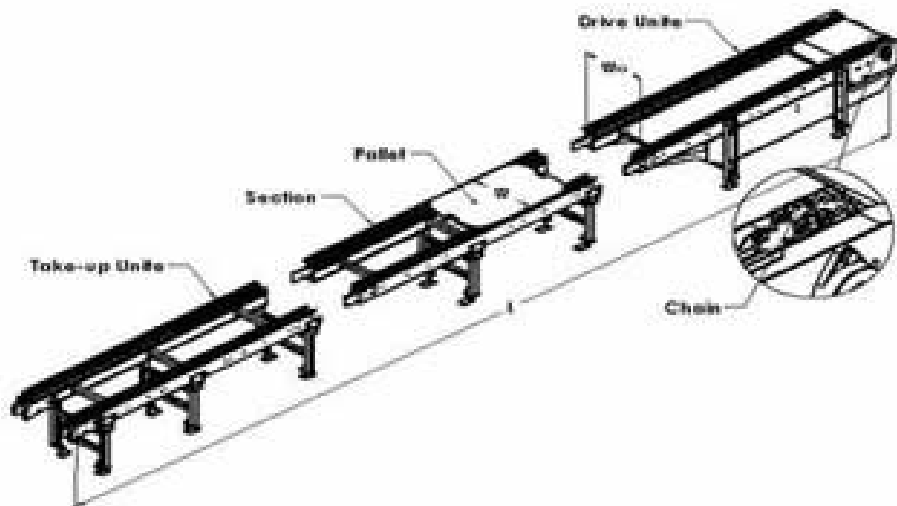

Loading Capacity	16,000 N/m
Linear Speed	From 5 m/min to 15 m/min. approximately.
Chain Type	10B-2
Chain Support	UHWPE Green, machined wear strip.
Mains Supply	380 VAC +/- 10%, 50 Hz, 3 Phase.
Motor Power	0.37 kW ~ 2.2 kW depending on length, linear speed and load.
Motor Class	IP54
Insulation Class	IP54
Painting	Electrostatic Epoxy Powder paint RAL 7035

# CHT Chain Conveyors

## Dimensions

Standard Width (W) / Preferred Values

Outer Distance (Wo)

W [mm] Nominal pallet width	800	1000	1200
Wo [mm]	767	966	1167

## Note:

The CHT family's Side Channels, are made in modules of 2490 mm length. Standard Section Lengths can be combined to obtain the nearest required length.

Modules are attached together using Butt Couplings, to obtain any desired length.

## Options

Floor Supports	SGH
Ceiling Hangers	No
Wall Mount	No
Brake Motor	Yes
Bidirectional motion	No
Variable Speed Drives	Yes

## Accessories

Butt Coupling	Yes
Push Button Station	Yes
Emergency Pull Cord	No
Optical Switches and Controls	Yes
End Stops	Yes
Guard Rails	Yes

مكتب القاهرة : برج القانوين كورنيش المعادى  
تليفون : ٠٢/٢٥٢٦٦٣٣٣  
فاكس : ٠٢/٢٥٢٦٤٨٨٨

مدينة برج العرب الجديدة - المنطقة الصناعية الثانية  
يونيتل/ مدخل ٢ شارع ٣ - مدخل ٢ شارع ٥  
تليفون : ٠٣/٤٦٢٤٤٢٤-٤٦٢٤٠٢٥-٤٦٢٤١٢٦-٤٦٢٤١٢٧  
فاكس : ٠٣/٤٦٢٤٢٩١



[www.UnitelEgypt.com](http://www.UnitelEgypt.com)



/UnitelEgypt

[Sales@UnitelEgypt.com](mailto:Sales@UnitelEgypt.com)

[Info@UnitelEgypt.com](mailto:Info@UnitelEgypt.com)